

*TB 9-6625-1356-35

DEPARTMENT OF THE ARMY TECHNICAL BULLETIN

CALIBRATION PROCEDURE FOR TEST OSCILLATOR, HEWLETT-PACKARD MODELS 651A, 651B AND 652A (SG-763/U)

Headquarters Department of the Army, Washington, DC

5 May 2004

Distribution Statement A: Approved for public release; distribution is unlimited.

REPORTING OF ERRORS AND RECOMMENDING IMPROVEMENTS

You can improve this manual. If you find any mistakes or if you know of a way to improve these procedures, please let us know. Mail your letter or DA Form 2028 (Recommended Changes to Publications and Blank Forms) directly to: Commander, US Army Aviation and Missile Command, AMSAM-MMC-MA-NP, Redstone Arsenal, AL 35898-5000. A reply will be furnished to you. You may also provide DA Form 2028 information to AMCOM via e-mail, fax, or the World Wide Web. Our fax number is DSN 788-6546 or Commercial 256-842-6546. Our e-mail address is 2028@redstone.army.mil. Instructions for sending an electronic 2028 may be found at the back of this manual. For the World Wide Web, use <https://amcom2028.redstone.army.mil>.

SECTION		Paragraph	Page
I.	IDENTIFICATION AND DESCRIPTION		
	Test instrument identification	1	2
	Forms, records, and reports	2	2
	Calibration description	3	2
II.	EQUIPMENT REQUIREMENTS		
	Equipment required	4	3
	Accessories required	5	3
III.	CALIBRATION PROCESS		
	Preliminary instructions	6	4
	Equipment setup	7	5
	Frequency accuracy and stability	8	5
	Output voltage, meter tracking and expanded scale	9	9

*This technical bulletin supersedes TB 9-6625-1356-35, 27 February 1989, including all changes.

Frequency response.....	10	10
Expand monitor flatness model 652A (SG-763/U) only	11	11
Distortion	12	12
Output attenuator accuracy	13	13
Power supply	14	16
Final procedure	15	16

**SECTION I
IDENTIFICATION AND DESCRIPTION**

1. Test Instrument Identification. This bulletin provides instructions for the calibration of Test Oscillator, Hewlett-Packard Models 651A, 651B and 652A (SG-763/U). The manufacturers' manuals were used as the prime data sources in compiling these instructions. The equipment being calibrated will be referred to as the TI (test instrument) throughout this bulletin.

a. Model Variations. Variations among models are described in text, tables and figures.

b. Time and Technique. The time required for this calibration is approximately 8 hours, using the dc and low frequency technique.

2. Forms, Records, and Reports

a. Forms, records, and reports required for calibration personnel at all levels are prescribed by TB 750-25.

b. Adjustments to be reported are designated (R) at the end of the sentence in which they appear. When adjustments are in tables, the (R) follows the designated adjustment. Report only those adjustments made and designated with (R).

3. Calibration Description. TI parameters and performance specifications which pertain to this calibration are listed in table 1.

Table 1. Calibration Description

Test instrument parameters	Performance specifications
Frequency Dial Accuracy	Range: 100 Hz to 1 MHz Accuracy: $\pm 2\%$ ($\pm 10\%$ for line variation) Range: 10-100 Hz and 1-10 MHz Accuracy: $\pm 3\%$ ($\pm 10\%$ for line variation)
Attenuator: ¹ Model 651B and 652A (SG-763/U) Models 651A	Range: -70 to +20 dBm Accuracy: $\pm .075$ dBm from -60 to +20 dBm Range: -70 to +20 dBm Accuracy: ± 0.1 dB/10 dB

See footnotes at end of table.

Table 1. Calibration Description - Continued.

Test instrument parameters	Performance specifications
Distortion Model 651B and 652A (SG-763/U) Models 651A	Range: 10 Hz to 2 MHz Accuracy: <1% Range: 2 to 5 MHz Accuracy: <2% Range: 5 to 10 MHz Accuracy: <4% Range: 10 Hz to 5 MHz Accuracy: ±1% Approximately 2% at 10 MHz
Output Monitor Model 651B and 652A (SG-763/U) only	Range: 0.9 to 1 V (or 2.8 to 3.2 V) Accuracy: ±2% FS
Output Monitor Flatness Model 651B and 652A (SG-763/U) only	Frequency range: 10 Hz to 10 MHz Range: 3 and 1 V ² Accuracy: ±0.25% Range: .3 to .3 mV Accuracy: ±0.75% Range: .1 mV Accuracy: ±1.75%
Frequency Response Model 651B and 652A (SG-763/U) Models 651A	Range: 1 to 3 V ³ Frequency: 10-20 Hz and 4-10 MHz Accuracy: ±2% Frequency: 20 Hz-4 MHz Accuracy: ±1% Range: 1 to 3 V ³ Frequency: 10 to 100 Hz Accuracy: ± 3% Frequency: 100 Hz to 4 MHz Accuracy: ± 2% Frequency: 4 to 10 MHz Accuracy: ± 4%

¹Procedure limitation: Certification from -50 to +20 dB only.

²Amplitude readjusted using expanded scale on output monitor.

³Specification is verified on the 3-V range only.

SECTION II EQUIPMENT REQUIREMENTS

4. Equipment Required. Table 2 identifies the specific equipment to be used in this calibration procedure. This equipment is issued with Secondary Transfer Calibration Standards Set AN/GSM-286; AN/GSM-287; or AN/GSM-705. Alternate items may be used by the calibrating activity. The items selected must be verified to perform satisfactorily prior to use and must bear evidence of current calibration. The equipment must meet or exceed the minimum use specifications listed in table 2. The accuracies listed in table 2 provide a four-to-one ratio between the standard and TI. Where the four-to-one ratio cannot be met, the actual accuracy of the equipment selected is shown in parenthesis.

5. Accessories Required. The accessories required for this calibration are common usage accessories issued as indicated in paragraph 4 above, and are not listed in this calibration procedure.

Table 2. Minimum Specifications of Equipment Required

Common name	Minimum use specifications	Manufacturer and model (part number)
ATTENUATOR	Range: 0 to 80 dB Accuracy: ± 0.05 dB ($\pm .1$ dB/10 dB)	Hewlett-Packard, Model 355D (355D) or RLC Electronics, Model A2648 (MIS-10263)
AUDIO ANALYZER	Range: 10 Hz to 10 MHz ¹ Accuracy: <0.25% distortion	Boonton, Model 1121 (1121)
AUTOTRANSFORMER	Range: 105 to 125 V ac Accuracy: $\pm 1\%$	General Radio, Type W10MT3AS3 (7910809) or Ridge, Model 9020F (9020A)
CALIBRATOR	Range: 2.40 to 2.60 V dc Accuracy: $\pm 2\%$	Fluke, Model 5720A (5700A/EP) (p/o MIS 35947)
FREQUENCY COUNTER	Range: 9.7 Hz to 10.3 MHz Accuracy: $\pm 5\%$	Fluke, PM6681/656 (PM6681/656)
MULTIMETER	Range: 7 mV to 30.9 V dc 100 mV to 3.2232 V ac Accuracy: $\pm 1.5\%$ dc $\pm 0.5\%$ ac	Hewlett-Packard, Model 3458A (3458A)
THERMAL CONVERTER	Range: 10 Hz to 10 MHz Accuracy: $\pm 0.0625\%$ to 100 kHz $\pm 0.2\%$ to 1 MHz $\pm 0.4\%$ to 10 MHz	Ballantine, Model 1395A-3/1395-3 (7913198-1)
TRUE RMS VOLTMETER	Range: 1 mV Resolution: At least 2 μ V	Fluke, Model 8922A/AA (8922A/AA)

¹When certified between 10 Hz and 500 kHz, there is a sufficient confidence factor that distortion will be within tolerance up to 10 MHz.

SECTION III CALIBRATION PROCESS

6. Preliminary Instructions

a. The instructions outlined in paragraphs 6 and 7 are preparatory to the calibration process Personnel should become familiar with the entire bulletin before beginning the calibration.

b. Items of equipment used in this procedure are referenced within the text by common name as listed in table 2.

c. Unless otherwise specified, verify the result of each test and, whenever the test requirement is not met, take corrective action before continuing with the calibration. Adjustments required to calibrate the TI are included in this procedure. Additional maintenance information is contained in the manufacturers' manuals for this TI.

d. When indications specified in paragraphs **8** through **13** are not within tolerance, perform the power supply check prior to making adjustments. After adjustments are made, repeat paragraphs **8** through **13**. Do not perform power supply check if all other parameters are within tolerance.

e. Unless otherwise specified, all controls and control settings refer to the TI.

7. Equipment Setup

WARNING

HIGH VOLTAGE is used or exposed during the performance of this calibration. DEATH ON CONTACT may result if personnel fail to observe safety precautions. REDUCE OUTPUT(S) to minimum after each step within the performance checks where applicable.

NOTE

Remove TI protective cover only to make connections or adjustments. Reinstall protective cover immediately after connection or adjustment.

a. Rotate **AMPLITUDE** controls fully ccw. Set **LINE** switch to off.

b. Set 115/230 slide switch (rear panel) to 115.

c. Connect autotransformer to TI.

d. Connect autotransformer to a 115 ac power source and adjust control for a 115 V ac output.

e. Set **LINE** switch to **ON** and allow sufficient time for warm-up and stabilization.

f. Set **LINE** switch to off (down) and wait 30 seconds.

g. (Hewlett-Packard, Model 651A) If necessary, turn meter mechanical zero adjustment screw cw until meter pointer is on 0 (zero).

h. (Hewlett-Packard, Model 651A) Turn adjustment screw approximately 15 degrees ccw. If meter pointer moves, repeat **g** above and this step.

i. (All other models) insert pointed object into recess on adjustment wheel and rotate wheel until meter pointer is exactly over 0.

j. Set **LINE** switch to **ON**.

8. Frequency Accuracy and Stability

a. Performance Check

(1) Connect frequency counter to TI using a 50 Ω feed-through termination.

TB 9-6625-1356-35

(2) Position controls as listed in (a) through (d) below:

- (a) **FREQUENCY RANGE** switch to **X1K**.
- (b) **FREQUENCY** dial to **1**.
- (c) (Model 652A) **OUTPUT MONITOR** switch to **NORMAL**.
- (d) **OUTPUT ATTENUATOR** switch to **3.0 VOLTS**.

(3) Adjust **AMPLITUDE** controls for a 3.0 V indication on TI meter. If frequency counter does not indicate between 980 and 1020 Hz, perform **b** below.

(4) Vary autotransformer output from 105 to 125 V and back to 115 V. Frequency counter indication will remain between 980 and 1020 Hz.

(5) Repeat technique of (3) above for **FREQUENCY RANGE** and **FREQUENCY** dial settings listed in table 3. If frequency counter does not indicate within limits specified, perform **b** below.

Table 3. Frequency Accuracy Check

Test instrument		Frequency counter indications	
FREQUENCY RANGE switch settings	FREQUENCY dial settings	Min	Max
X10	1	9.70 Hz	10.31 Hz
X10	5	48.54 Hz	51.55 Hz
X10	10	97.08 Hz	103.09 Hz
X100	1	98.03 Hz	102.05 Hz
X100	5	490.19 Hz	510.20 Hz
X100	10	.980 kHz	1.02 kHz
X1K	5	4.90 kHz	5.10 kHz
X1K	10	9.80 kHz	10.20 kHz
X10K	10	98.00 kHz	102.00 kHz
X10K	5	49.00 kHz	51.00 kHz
X10K	1	9.80 kHz	10.20 kHz
X100K	1	98.00 kHz	102.00 kHz
X100K	5	490.00 kHz	510.00 kHz
X100K	10	0.98 MHz	1.02 MHz
X1M	10	9.70 MHz	10.30 MHz
X1M	5	4.85 MHz	5.15 MHz
X1M	1	0.97 MHz	1.03 MHz

b. Adjustments

- (1) Remove TI bottom cover and oscillator shield.
- (2) Connect multimeter with a 1 k Ω resistor in series between A2TP1 (fig. 1) and chassis ground.
- (3) Connect audio analyzer to TI using a 50 Ω feed-through termination.

- (4) Position controls as listed in (fig. 2) below.
- (5) Adjust **AMPLITUDE** controls for a 3.0 V indication on TI meter. Multimeter will indicate between 100 and 120 mV ac.
- (6) Adjust A2R17 (fig. 1) for minimum distortion (R).
- (7) Connect multimeter between A2TP2 (fig. 1) and chassis ground.
- (8) Connect frequency counter to TI, using a 50 Ω feed-through termination.
- (9) Turn **FREQUENCY** dial to 10.
- (10) Adjust S1C2 and S1C7 (fig. 2) alternately until multimeter indicates -350 mV and frequency counter indicates 10.0 kHz (R).

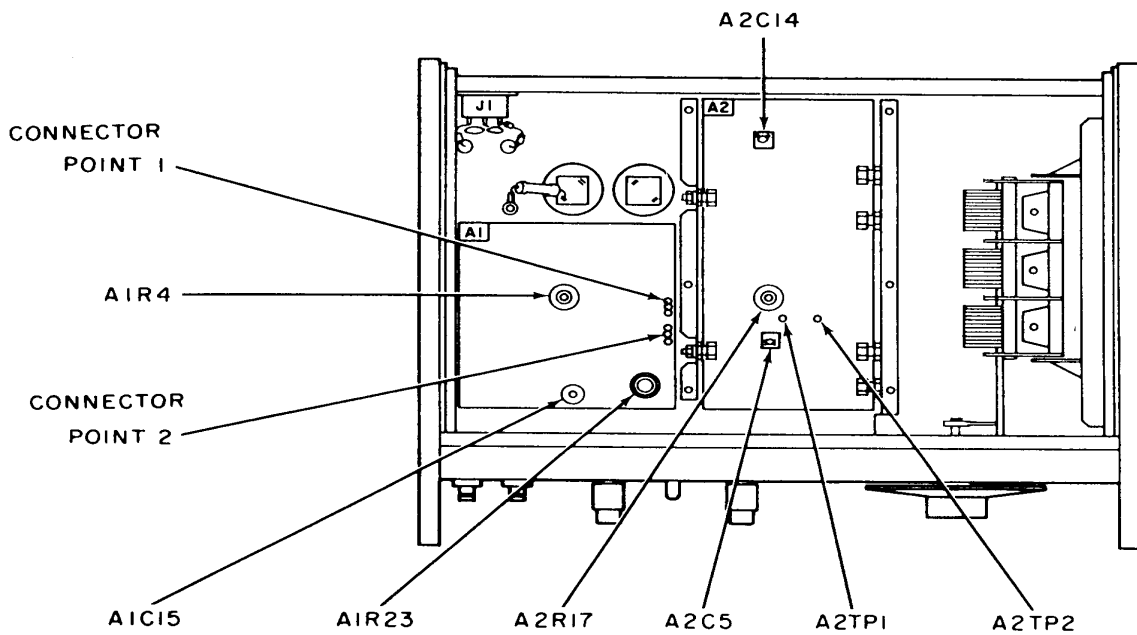

Figure 1. Test instrument - bottom view.

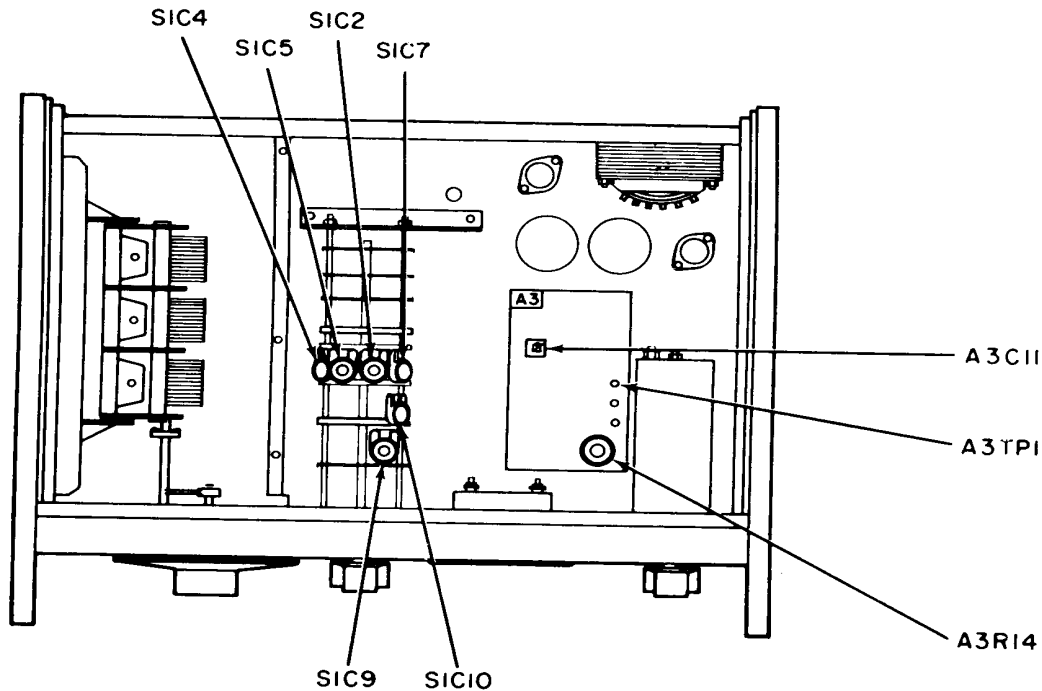

Figure 2. Test instrument - top view.

NOTE

On some instruments, the voltage at A2TP2 may not be within limits indicated in (10) above. If voltage is not less than -200 mV, and output flatness and distortion specifications are met, the instrument will be considered acceptable.

- (11) Turn **FREQUENCY** dial to 1.
- (12) Readjust S1C2 and S1C7 until multimeter indicates -350 mV and frequency counter indicates 1.00 kHz.
- (13) Turn **FREQUENCY** dial until frequency counter indicates 5.0 kHz.
- (14) Remove **FREQUENCY** dial knob and loosen four dial retaining screws. Slip **FREQUENCY** dial until 5 on dial is aligned with reference marker. Tighten retaining screws and reinstall **FREQUENCY** dial knob.
- (15) Repeat (9) through (14) above until TI is within tolerance in (10) and (12) above.

NOTE

S1C2 and S1C7 are the only adjustments for X10, X100, X1K, and X10K ranges.

- (16) Set **FREQUENCY RANGE** switch to **X1M** and turn **FREQUENCY** dial to 10.

NOTE

During remaining adjustments, remove TI top or bottom cover to make adjustments. Reinstall covers for measurements.

NOTE

During remaining adjustments, remove TI top or bottom cover to make adjustments. Reinstall covers for measurements.

(17) Adjust S1C5 (fig. 2) and A2C5 (fig. 1) alternately until frequency counter indicates 10.0 MHz and multimeter indicates -370 mV (R).

NOTE

If TI will not oscillate, adjust S1C10 (fig. 2) slightly.

(18) Turn **FREQUENCY** dial to 1.

(19) If necessary, readjust S1C5 and A2C5 alternately until frequency, counter indicates 1.0 MHz: and multimeter indicates -350 mV (R).

NOTE

Repeat (16) and (17) above if S1C5 and/or A2C5 were adjusted in (19) above.

(20) Turn **FREQUENCY** dial to 5.

(21) Adjust S1C10 (fig. 2) until frequency counter indicates 5.0 MHz and multimeter indicates -310 MHz (R).

(22) Repeat (16) through (21) above until no further adjustment is required.

(23) Set **FREQUENCY RANGE** switch to **X100K** and turn **FREQUENCY** dial to **10**.

(24) Adjust S1C4 and S1C9 (fig. 2) until frequency counter indicates 1.00 MHz and multimeter indicates -275 mV (R).

9. Output Voltage, Meter Tracking and Expanded Scale

a. Performance Check

(1) Connect multimeter to TI, using a 50 Ω feed-through termination.

(2) Set **FREQUENCY RANGE** switch to **X100** and turn **FREQUENCY** dial to 4.

(3) Rotate **AMPLITUDE** controls fully cw. Multimeter will indicate at least 3.16 V ac.

(4) Adjust **AMPLITUDE** controls for a 3 V indication on TI meter. If multimeter does not indicate between 2.94 and 3.06 V ac, perform **b** (1) and (2) below.

(5) Repeat technique of (4) above for TI meter indications listed in table 4. Multimeter will indicate within limits specified.

Table 4. Meter Tracking

Test instrument meter indications (0 to 3 scale)	Multimeter indications (V ac)	
	Min	Max
2.5	2.44	2.56
2.0	1.94	2.06
1.5	1.44	1.56
1.0	0.94	1.06
0.5	0.44	0.56

NOTE

Perform (6) and (7) below for Model 652A only.

- (6) Position controls as listed in (a) through (e) below:
- (a) **FREQUENCY RANGE** switch to **X10K**.
 - (b) **FREQUENCY** dial to **1**.
 - (c) **OUTPUT AMPLITUDE** and **VERNIER** controls for a 2.925 V indication on multimeter.
 - (d) **OUTPUT MONITOR** switch to **EXPAND**.
 - (e) **REF SET** and **VERNIER** controls for a -2.5 indication on TI percent scale.

(7) Adjust **OUTPUT AMPLITUDE** and **VERNIER** controls for a +2.5 indication on meter percent scale. If multimeter does not indicate between 3.0690 and 3.0810 V, perform **b** (3) and (4) below.

b. Adjustments

- (1) Adjust **AMPLITUDE** controls for a 3.00 V indication on multimeter.
- (2) Adjust A1R23 (fig. 1) for a 3 V indication on TI meter (R).
- (3) Adjust **OUTPUT AMPLITUDE** and **VERNIER** controls for a 3.075 V indication on multimeter.
- (4) Adjust A3R14 (fig. 2) for a +2.5 indication on TI meter percent scale (R).

10. Frequency Response

a. Performance Check

- (1) Connect thermal converter to TI 50 Ω connector.
- (2) Connect multimeter to thermal converter output.
- (3) Set **FREQUENCY RANGE** switch to **X100** and turn **FREQUENCY** dial to **4**.
- (4) Set **OUTPUT MONITOR** switch to **NORMAL** (Model 652A only).
- (5) Adjust **AMPLITUDE** controls for a 2.40 V indication on TI meter. Record multimeter indication (reference voltage).
- (6) Connect thermal converter to calibrator.
- (7) Connect multimeter to thermal converter output.
- (8) Adjust controls of calibrator until multimeter reference voltage indication is same as recorded in (5) above.
- (9) Adjust controls of calibrator for +2 percent of indicated voltage. Record multimeter indication.
- (10) Adjust controls of calibrator for -2 percent of indicated voltage.
- (11) Repeat technique of (9) and (10) above for reference voltage + (plus) and - (minus) 1, 3, and 4 percent (3 and 4 percent only for Model 651A).

- (12) Connect thermal converter input to TI 50 Ω connector.
- (13) Connect multimeter to thermal converter output.
- (14) Set **FREQUENCY RANGE** switch and **FREQUENCY** dial for settings listed in table 5 while adjusting **AMPLITUDE** controls for a 2.4 V indication on TI meter at each setting. If multimeter does not indicate within limits recorded in (9) through (11) above for + (plus) and - minus perform **b** below.

CAUTION

Adjust **AMPLITUDE** controls for minimum output when changing **FREQUENCY RANGE** switch setting.

Table 5. Frequency Response

Test instrument		Multimeter indications	
FREQUENCY RANGE switch settings	FREQUENCY dial settings	Hewlett-Packard model 651A	All other models
X10	2	±3%	±2%
X10	1	±3%	±2%
X100	1	±2%	±1%
X1K	5	±2%	±1%
X10K	5	±2%	±1%
X100K	5	±2%	±1%
X1M	1	±2%	±1%
X1M	4	±4%	±2%
X1M	6	±4%	±2%
X1M	8	±4%	±2%
X1M	10	±4%	±2%

b. Adjustments

- (1) Adjust A2C14 (fig. 1) fm best overall flatness between 1 and 10 MHz.
- (2) Set **FREQUENCY RANGE** switch to **X1M** and turn **FREQUENCY** dial to **10**.
- (3) Adjust **AMPLITUDE** controls for multimeter indication recorded in **a** (5) above.
- (4) Adjust A1C15 (fig. 1) for a 2.40 V indication on TI meter (R).

11. Expand Monitor Flatness (Model 652A (SG-763/U) Only)

a. Performance Check

- (1) Connect multimeter to TI using a 50 Ω feed-through termination.
- (2) Position controls as listed in (a) through (f) below:
 - (a) **FREQUENCY RANGE** switch to **X100**.
 - (b) **FREQUENCY** dial to 4.
 - (c) **AMPLITUDE** controls for a 3.00 V indication on multimeter.
 - (d) **NORMAL-EXPAND** switch to **EXPAND**.
 - (e) **REF SET** control for a 0 indication on TI meter expand scale.

NOTE

Do not change **REF SET** controls throughout remainder of test.

(f) **AMPLITUDE** controls for minimum output.

(3) Substitute thermal converter for 50 Ω feed-through termination. Adjust **AMPLITUDE** controls for 0 indication on TI meter expand scale. Record multimeter indication.

(4) Set **FREQUENCY RANGE** switch to **X1M** and turn **FREQUENCY** dial to **10**.

(5) Adjust **AMPLITUDE** controls until multimeter indication equals:

$$A - \left[\frac{2B}{100} \times A \right]$$

Where: A = value recorded in (3) above.

B = AC/DC test report correction in percent

Example:

A = 7 mV

B = -0.1

7 - (0.002 x 7)

7 - (0.014) = 7.014 mV

(6) If TI meter does not indicate between -0.25 and +0.25 percent on expand scale, perform **b** below.

(7) Repeat technique of (4) through (6) above for **FREQUENCY RANGE** and **FREQUENCY** dial settings listed in table 6. TI meter will indicate between -0.25 and +0.25 percent on expand scale.

Table 6. Expand Frequency Response

Test instrument	
FREQUENCY RANGE switch settings	FREQUENCY dial settings
X1M	3
X1M	1
X100K	1
X10K	5
X10K	1
X10	5

b. Adjustments. Adjust A3C11 (fig. 2) for a 0 indication on TI meter expand scale (R).

12. Distortion

a. Performance Check

(1) Connect audio analyzer to TI using a 50 Ω feed-through termination.

(2) Position controls as listed in (a) through (c) below:

(a) **FREQUENCY RANGE** switch to **X1K**.

(b) **FREQUENCY** dial to **1**.

(c) (Model 652A (SG-763/U)) **OUTPUT MONITOR** switch to **NORMAL**.

(3) Adjust **AMPLITUDE** controls for a 3.0 V indication on TI meter. If audio analyzer does not indicate less than 1 percent distortion, perform **b** below.

(4) Repeat (3) above at **FREQUENCY RANGE** switch and **FREQUENCY** dial settings listed in table 7. Audio analyzer will indicate less than 1 percent distortion.

Table 7. Distortion Check

Test instrument	
FREQUENCY RANGE switch settings	FREQUENCY dial settings
X10	5
X10	10
X100	1
X100	10
X1K	10
X10K	1
X10K	2
X100K	1
X100K	5

b. Adjustments. Adjust A2R17 (fig. 1) for minimum distortion indication on audio analyzer (R).

13. Output Attenuator Accuracy

a. Performance Check

- (1) Adjust **AMPLITUDE** controls for minimum output.
- (2) Connect equipment as shown in figure 3.

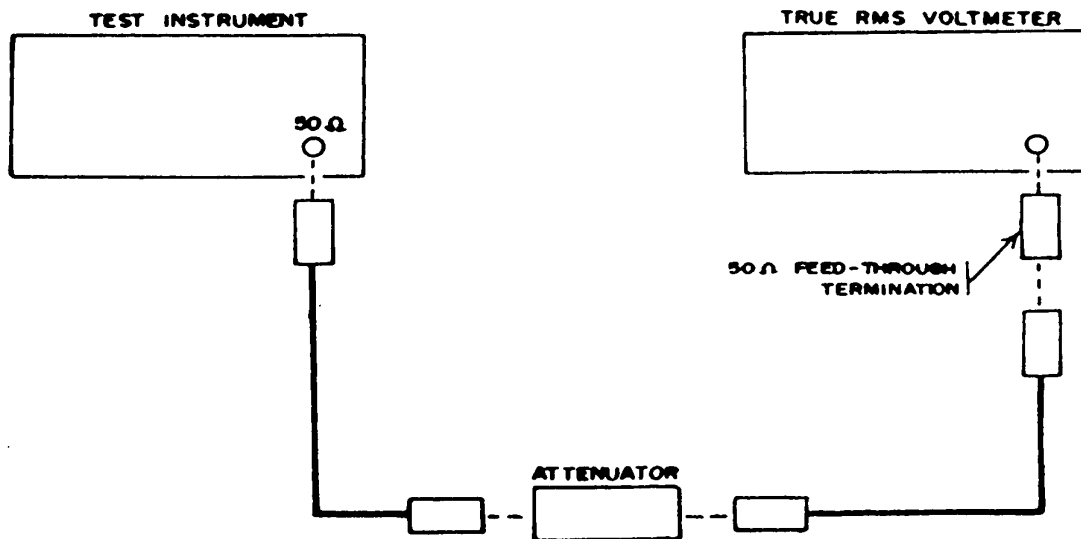

Figure 3. Output attenuator - equipment setup.

TB 9-6625-1356-35

- (3) Position controls as listed in (a) through (c) below:
 - (a) **FREQUENCY RANGE** switch to **X1M**.
 - (b) **FREQUENCY** dial to **10**.
 - (c) **OUTPUT ATTENUATOR** switch to **+20 DBM**.
- (4) Adjust attenuator to 60 dB.
- (5) Adjust **AMPLITUDE** controls for a 1 mV reference indication on true rms voltmeter. Record exact indication.
- (6) Set **OUTPUT ATTENUATOR** switch to **+10 DBM**.
- (7) Adjust attenuator to 50 dB. Record true rms voltmeter indication.
- (8) Set **OUTPUT ATTENUATOR** switch to **0 DBM**.
- (9) Adjust attenuator to 40 dB. Record true rms voltmeter indication.
- (10) Repeat technique of (6) through (9) above for each **OUTPUT ATTENUATOR** switch setting from **-10** through **-40 DBM**.
- (11) Compute voltage difference between reference value recorded in (5) above and voltage value recorded for each **OUTPUT ATTENUATOR** switch setting checked.

Example:

Voltage obtained in (5) above = 1.0050 mV
 Voltage obtained at **OUTPUT ATTENUATOR -30 DBM** switch setting = 1.0095 mV
 Voltage difference = 1.0050 - 1.0095 = -4.5 μ V
 Voltage difference of -4.5 μ V yields 0.04 dB change as obtained from table 8

- (12) Refer to table 8 and record attenuation change. Designate attenuation change as +c if true rms voltmeter indicates a decrease from reference, and as -c if true rms voltmeter indicates an increase from reference.

Table 8. Voltage Change vs. Attenuation Change

Voltage difference (μ V)		Equivalent attenuation change in dB(c)
0	to 1.7	0.01
1.7	to 2.8	0.02
2.8	to 4.0	0.03
4.0	to 5.1	0.04
5.1	to 6.4	0.05
6.4	to 7.5	0.06
7.5	to 8.7	0.07
8.7	to 9.8	0.08
9.8	to 11.0	0.09
11.0	to 12.2	0.10
12.2	to 13.3	0.11
13.3	to 14.5	0.12
14.5	to 15.7	0.13
15.7	to 16.8	0.14

Table 8. Voltage Change vs. Attenuation Change Continued

Voltage difference (μV)	Equivalent attenuation change in dB(c)
16.8 to 18.0	0.15
18.0 to 19.2	0.16
19.2 to 20.4	0.17
20.4 to 21.5	0.18
21.5 to 22.7	0.19
22.7 to 23.3	0.20

(13) Refer to test report for attenuator and record the corrected attenuation value for 60 dB. Designate this value as a.

(14) Repeat (3) above for 50 dB. Designate this value as b.

(15) Using formula: Attenuation (a-b) ± c, determine attenuation value. This value will be within limits for the **OUTPUT ATTENUATOR** switch settings listed in table 9.

Table 9. Attenuator Accuracy

Test instrument OUTPUT ATTENUATOR switch settings (dBm)	Attenuator value limits (dB) ¹	
	Min	Max
+10	9.90 (9.92)	10.10 (10.08)
0	19.90 (19.92)	20.10 (20.08)
-10	29.90 (29.92)	30.10 (30.08)
-20	39.90 (39.92)	40.10 (40.08)
-30	49.90 (49.92)	50.10 (50.08)
-40	59.90 (59.92)	60.10 (60.08)

¹Values in parenthesis apply to Model 651B and 652A.

(16) Repeat (13) above for 40 dB. Designate this value as b.

(17) Repeat (15) above.

(18) Repeat technique of (16) and (17) above for each **OUTPUT ATTENUATOR** switch setting listed in table 9. Attenuation value will be within limits specified.

NOTE

Value a will remain the same for each check.

b. Adjustments. No adjustments can be made.

14. Power Supply

a. Performance Check

NOTE

Do not perform power supply check if all other parameters are within tolerance.

(1) Connect multimeter to CONNECTOR POINT 1 (fig. 1) and chassis ground. If multimeter does not indicate between 29.1 and 30.9 V, perform **b** below.

(2) Connect multimeter to CONNECTOR POINT 2 (fig. 1) and chassis ground. Multimeter will indicate between -24.25 and -25.75 V.

b. Adjustments. Adjust A1R4 (fig. 1) for a 30 V indication on multimeter (R).

15. Final Procedure

a. Deenergize and disconnect all equipment.

b. Annotate and affix DA label/form in accordance with TB 750-25.

By Order of the Secretary of the Army:

Official:

PETER J. SCHOOMAKER

*General, United States Army
Chief of Staff*



JOEL B. HUDSON

*Administrative Assistant to the
Secretary of the Army*

0406404

Distribution:

To be distributed in accordance with the initial distribution number (IDN) 342128, requirements for calibration procedure TB 9-6625-1356-35.

INSTRUCTIONS FOR SUBMITTING AN ELECTRONIC 2028

The following format must be used if submitting an electronic 2028. The subject line must be exactly the same and all fields must be included; however, only the following fields are mandatory: 1, 3, 4, 5, 6, 7, 8, 9, 10, 13, 15, 16, 17, and 27.

From: "Whomever" whomever@redstone.army.mil
To: <2028@redstone.army.mil

Subject: DA Form 2028

1. **From:** Joe Smith
2. **Unit:** home
3. **Address:** 4300 Park
4. **City:** Hometown
5. **St:** MO
6. **Zip:** 77777
7. **Date Sent:** 19-OCT -93
8. **Pub no:** 55-2840-229-23
9. **Pub Title:** TM
10. **Publication Date:** 04-JUL-85
11. **Change Number:** 7
12. **Submitter Rank:** MSG
13. **Submitter FName:** Joe
14. **Submitter MName:** T
15. **Submitter LName:** Smith
16. **Submitter Phone:** 123-123-1234
17. **Problem:** 1
18. **Page:** 2
19. **Paragraph:** 3
20. **Line:** 4
21. **NSN:** 5
22. **Reference:** 6
23. **Figure:** 7
24. **Table:** 8
25. **Item:** 9
26. **Total:** 123
27. **Text**

This is the text for the problem below line 27.

